

General Description

The AAT3159 is a low noise, constant frequency charge pump DC/DC converter that uses a tri-mode load switch (1X), fractional (1.5X), and doubling (2X) conversion to maximize efficiency for white LED applications. The device is capable of driving up to four channels of LEDs at up to 40mA per channel from a 2.7V to 5.5V input supply voltage. The current sinks may be operated individually or in parallel for driving higher-current LEDs. A low external parts count (two 1μF flying capacitors [C1 and C2] and two small 1μF capacitors [C_{IN} and C_{OUT}]) makes this part ideally suited for small battery-powered applications.

AnalogicTech’s patented single-wire Simple Serial Control™ (S²Cwire™) serial digital interface is used to enable, disable, and set the current for each LED with 16 levels from a maximum of 40mA down to 50μA. The maximum current level is programmed via an external resistor. To save power, low-current mode supply current will be as low as 50μA.

Each output of the AAT3159 is equipped with built-in protection for V_{OUT} short-circuit operation and auto-disable functionality for LED open-circuit conditions. Built-in soft-start circuitry prevents excessive inrush current during start-up. A low-current shutdown feature disconnects the load from IN and reduces quiescent current to less than 1μA.

The AAT3159 is available in a Pb-free, space-saving 2.85x3x1mm TSOPJW-14 package.

Typical Application

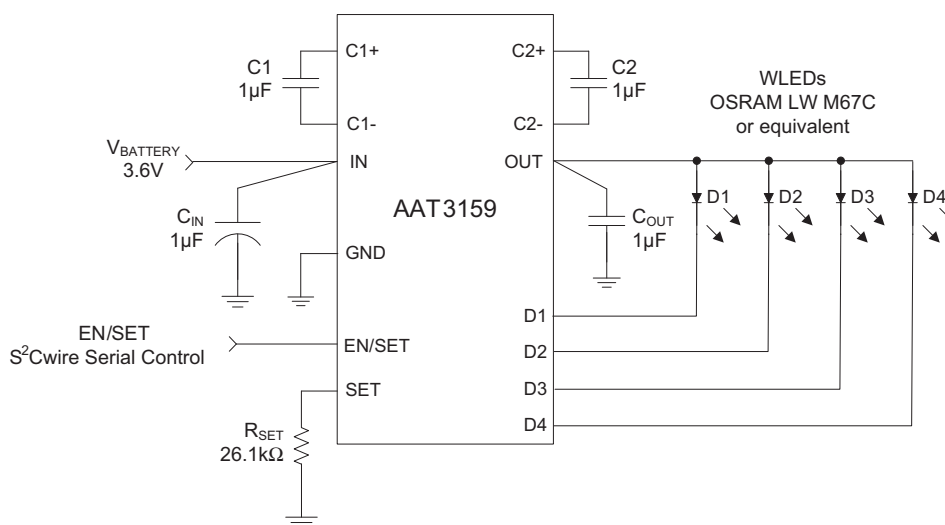

Features

- Input Supply Voltage Range: 2.7V to 5.5V
- Tri-Mode (1X/1.5X/2X) Charge Pump
 - Maximizes Efficiency
 - 1MHz Constant Switching Frequency
 - No Inductors, Low Noise Operation
- Drives Four Channels of LEDs up to 40mA/ Channel
 - User-Programmable LED Current
 - Excellent LED Channel-to-Channel Current Matching
- Digitally Programmable LED Current with Single-Wire S²Cwire Interface
 - 16 Current Levels From 40mA to 50μA
- Low I_Q (50μA) for Low Current Mode Operation
- True Load Disconnect in Shutdown; I_Q < 1μA
- Built-In Thermal Protection
- Built-In Auto-Disable for Open LED Circuit
- Automatic Soft-Start Minimizes Inrush Startup Current
- 2.85x3x1mm TSOPJW-14 Package

Applications

- Cellphones, DSC, Handheld Devices
- LED Photo Flash
- Programmable Current Sinks
- White LED Backlighting

Pin Descriptions

Pin #	Symbol	Function
1	D4	Current sink input #4. Connect to the cathode of LED4. If not used, connect D4 to the OUT pin.
2	SET	LED current setting resistor input/connection.
3	EN/SET	S ² Cwire serial interface control input for LED current magnitude control.
4	C1+	Positive terminal of charge pump capacitor 1.
5	C1-	Negative terminal of charge pump capacitor 1.
6	OUT	Charge pump output. Connect all LED anodes to OUT.
7	C2+	Positive terminal of charge pump capacitor 2.
8	C2-	Negative terminal of charge pump capacitor 2.
9, 11	GND	Ground.
10	IN	Input power supply connection.
12	D1	Current sink input #1. Connect to the cathode of LED1. If not used, connect D1 to the OUT pin.
13	D2	Current sink input #2. Connect to the cathode of LED2. If not used, connect D2 to the OUT pin.
14	D3	Current sink input #3. Connect to the cathode of LED3. If not used, connect D3 to the OUT pin.

Pin Configuration

**TSOPJW-14
(Top View)**

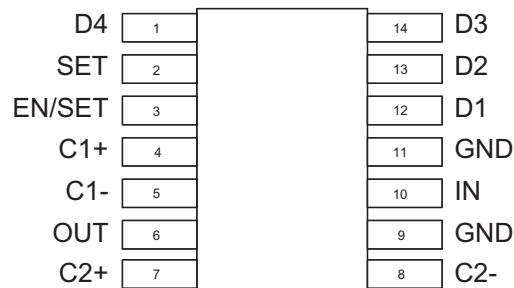

ChargePump™ High Efficiency 1X/1.5X/2X Charge Pump for White LED Applications
Absolute Maximum Ratings¹

Symbol	Description	Value	Units
V_N	[IN, OUT, D1, D2, D3, D4] to GND	-0.3 to 6	V
V_N	[C1-, C2-, EN/SET, SET] to GND	-0.3 to $V_{IN} + 0.3$	V
V_N	[C1+, C2+] to GND	-0.3 to $V_{OUT} + 0.3$	V
T_J	Operating Junction Temperature Range	-40 to 150	°C
T_{LEAD}	Maximum Soldering Temperature (at leads, 10 sec)	300	°C

Thermal Information²

Symbol	Description	Value	Units
P_D	Maximum Power Dissipation ³	0.625	W
θ_{JA}	Maximum Thermal Resistance	160	°C/W

1. Stresses above those listed in Absolute Maximum Ratings may cause permanent damage to the device. Functional operation at conditions other than the operating conditions specified is not implied. Only one Absolute Maximum Rating should be applied at any one time.

2. Mounted on a FR4 board.

3. Derate 6.25mW/°C above 25°C.



ChargePump™ High Efficiency 1X/1.5X/2X Charge Pump for White LED Applications

Electrical Characteristics¹

$V_{IN} = 3.6V$; $C_{IN} = C_{OUT} = C1 = C2 = 1.0\mu F$; $T_A = -40^{\circ}C$ to $+85^{\circ}C$, unless otherwise noted. Typical values are $T_A = 25^{\circ}C$.

Symbol	Description	Conditions	Min	Typ	Max	Units
Input Power Supply						
V_{IN}	Input Supply Voltage Range		2.7		5.5	V
I_{CC}	Operating Input Current	1X Mode, $3.0 \leq V_{IN} \leq 5.5$, Active, No Load Current		0.3	1	mA
		1.5X Mode, $3.0 \leq V_{IN} \leq 5.5$, Active, No Load Current		1	3	
		2X Mode, $3.0 \leq V_{IN} \leq 5.5$, Active, No Load Current		1		
	50 μA Setting, 1X Mode			50		μA
I_{SHDN}	Shutdown Current	EN/SET = 0			1	μA
I_{DX}	DX Pin Current	$T_A = -40^{\circ}C$ to $+85^{\circ}C$, $R_{SET} = 26.1k\Omega$, Data = 1 (100%)	18	20	22	mA
$I_{(D-Match)}$	Current Matching ²	$V_F:D1:D4 = 3.6V$		0.5	1	%
V_{TH}	1X to 1.5X or 1.5X to 2X Transition Threshold at Any DX Pin			150		mV
I_{SET}	Current Set Ratio	I_{SINK}/I_{RSET}		870		A/A
V_{SET}	SET Pin Voltage			0.6		V
Charge Pump Section						
T_{SS}	Soft-Start Time			100		μs
F_{CLK}	Clock Frequency			1000		kHz
EN/SET Logic Control						
$V_{IL(EN/SET)}$	Enable Logic Low Threshold	$V_{IN} = 2.7V$			0.4	V
$V_{IH(EN/SET)}$	Enable Logic High Threshold	$V_{IN} = 5.5V$	1.4			V
$T_{EN/SET LO}$	EN/SET Low Time		0.3		75	μs
$T_{EN/SET HI MIN}$	Minimum EN/SET High Time			50		ns
$T_{EN/SET HI MAX}$	Maximum EN/SET High Time				75	μs
T_{OFF}	EN/SET Off Timeout				500	μs
T_{LAT}	EN/SET Latch Timeout				500	μs
$I_{EN/SET}$	EN/SET Input Leakage		-1		1	μA

1. The AAT3159 is guaranteed to meet performance specifications over the $-40^{\circ}C$ to $+85^{\circ}C$ operating temperature range and is assured by design, characterization, and correlation with statistical process controls.
 2. Current matching is defined as the deviation of any sink current from the average of all active channels.

ChargePump™ High Efficiency 1X/1.5X/2X Charge Pump for White LED Applications

Typical Characteristics

$V_{IN} = 3.6V$; $C_{IN} = C_{OUT} = C1 = C2 = 1.0\mu F$; $T_A = -40^\circ C$ to $+85^\circ C$, unless otherwise noted. Typical values are $T_A = 25^\circ C$.

Efficiency vs. Input Voltage

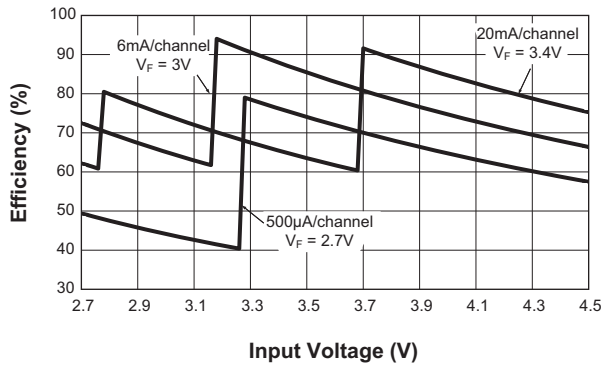

Turn-On to 1X Mode
($V_{IN} = 4.2V$; 20mA/Channel Load)

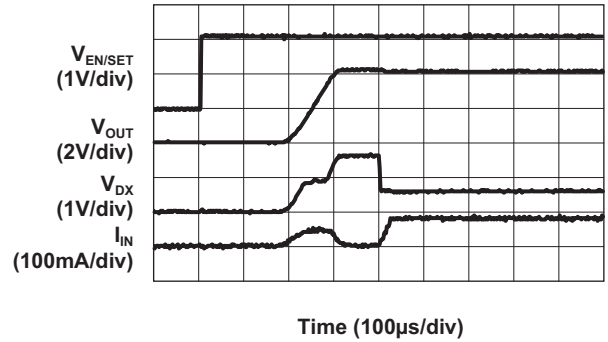

Turn-On to 1.5X Mode
($V_{IN} = 3.5V$; 20mA/Channel Load)

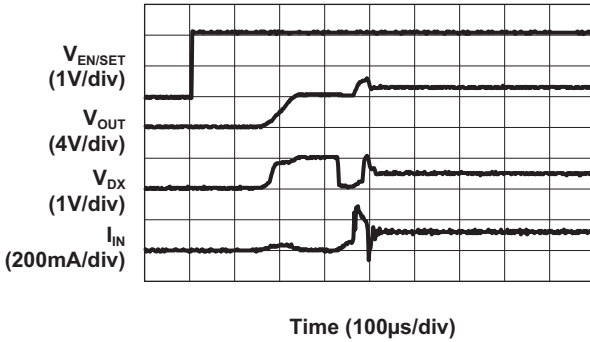

Turn-On to 2X Mode
($V_{IN} = 2.8V$; 20mA/Channel Load)

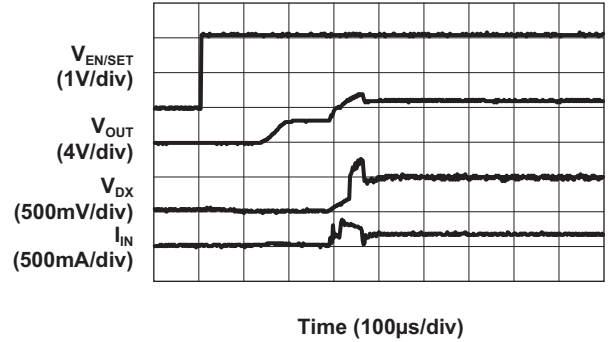

Turn-Off from 1.5X Mode
($V_{IN} = 3.5V$; 20mA/Channel Load)

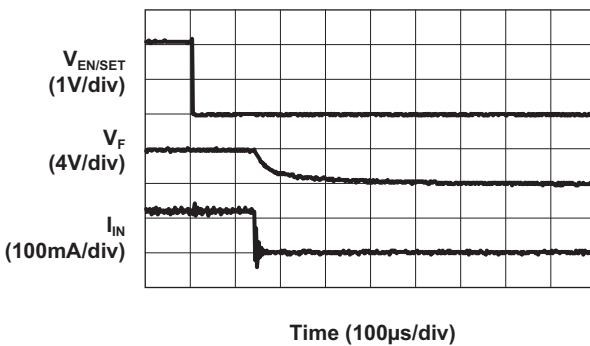

LED Current vs. Temperature
(20mA/Channel)

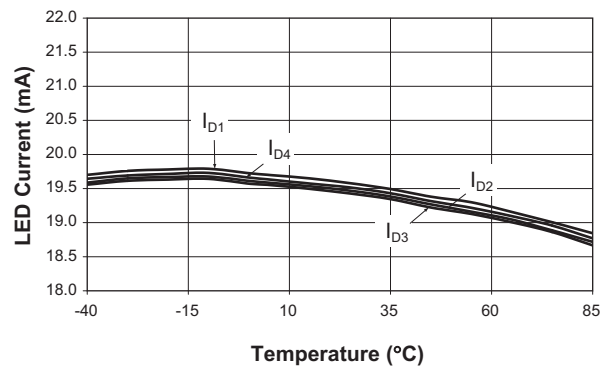

Typical Characteristics

$V_{IN} = 3.6V$; $C_{IN} = C_{OUT} = C1 = C2 = 1.0\mu F$; $T_A = -40^{\circ}C$ to $+85^{\circ}C$, unless otherwise noted. Typical values are $T_A = 25^{\circ}C$.

Operating Characteristics
($V_{IN} = 3.7V$; 1.5X Mode;
20mA/Channel Load; AC Coupled)

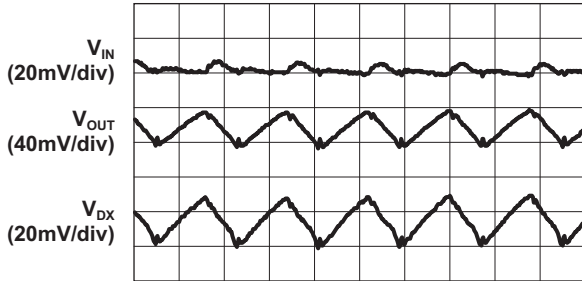

Time (500ns/div)

Operating Characteristics
($V_{IN} = 3.5V$; 1.5X Mode;
14mA/Channel Load; AC Coupled)

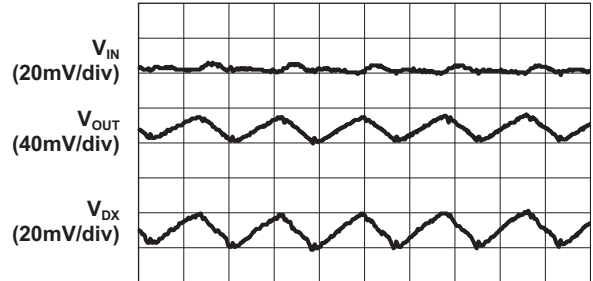

Time (500ns/div)

Operating Characteristics
($V_{IN} = 2.9V$; 2X Mode;
20mA/Channel Load; AC Coupled)

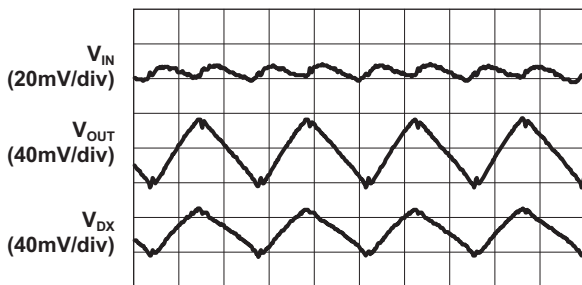

Time (500ns/div)

Operating Characteristics
($V_{IN} = 2.9V$; 2X Mode;
14mA/Channel Load; AC Coupled)

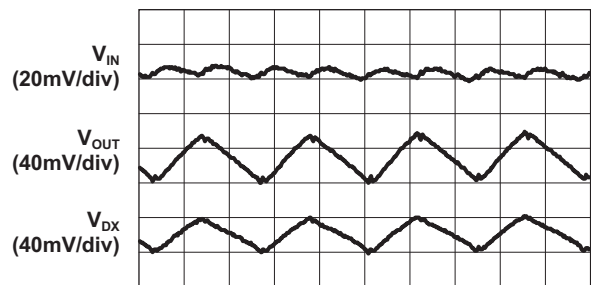

Time (500ns/div)

Input Ripple vs. Input Voltage

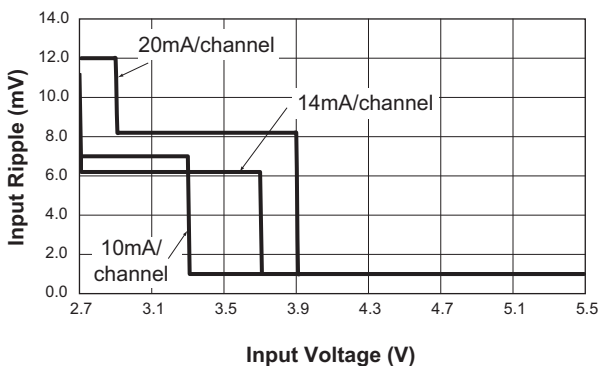

Typical Characteristics

$V_{IN} = 3.6V$; $C_{IN} = C_{OUT} = C1 = C2 = 1.0\mu F$; $T_A = -40^\circ C$ to $+85^\circ C$, unless otherwise noted. Typical values are $T_A = 25^\circ C$.

EN/SET Latch Timeout vs. Input Voltage

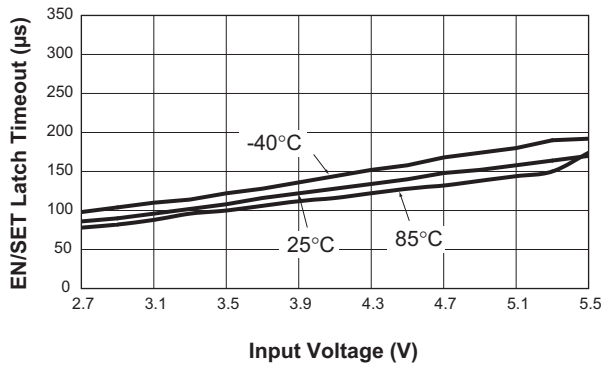

EN/SET Off Timeout vs. Input Voltage

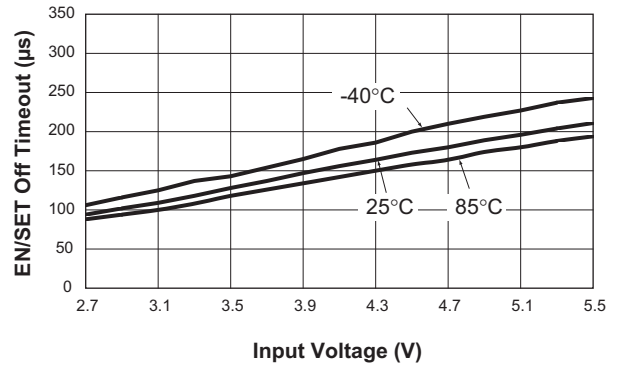

EN/SET High Threshold Voltage vs. Input Voltage

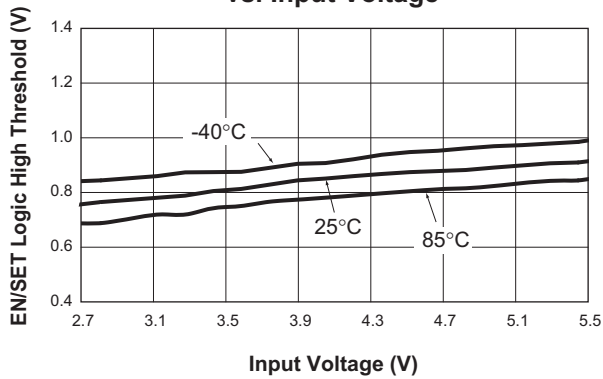

EN/SET Low Threshold Voltage vs. Input Voltage

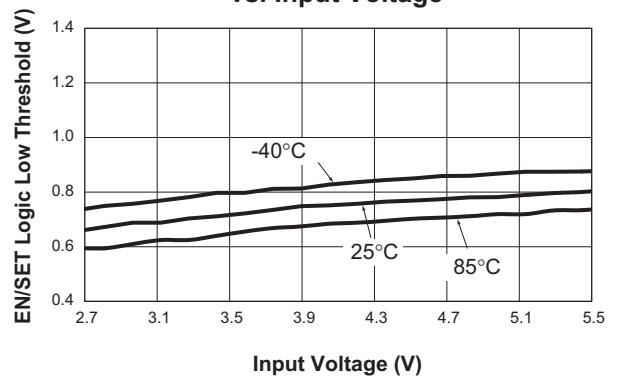

Functional Block Diagram

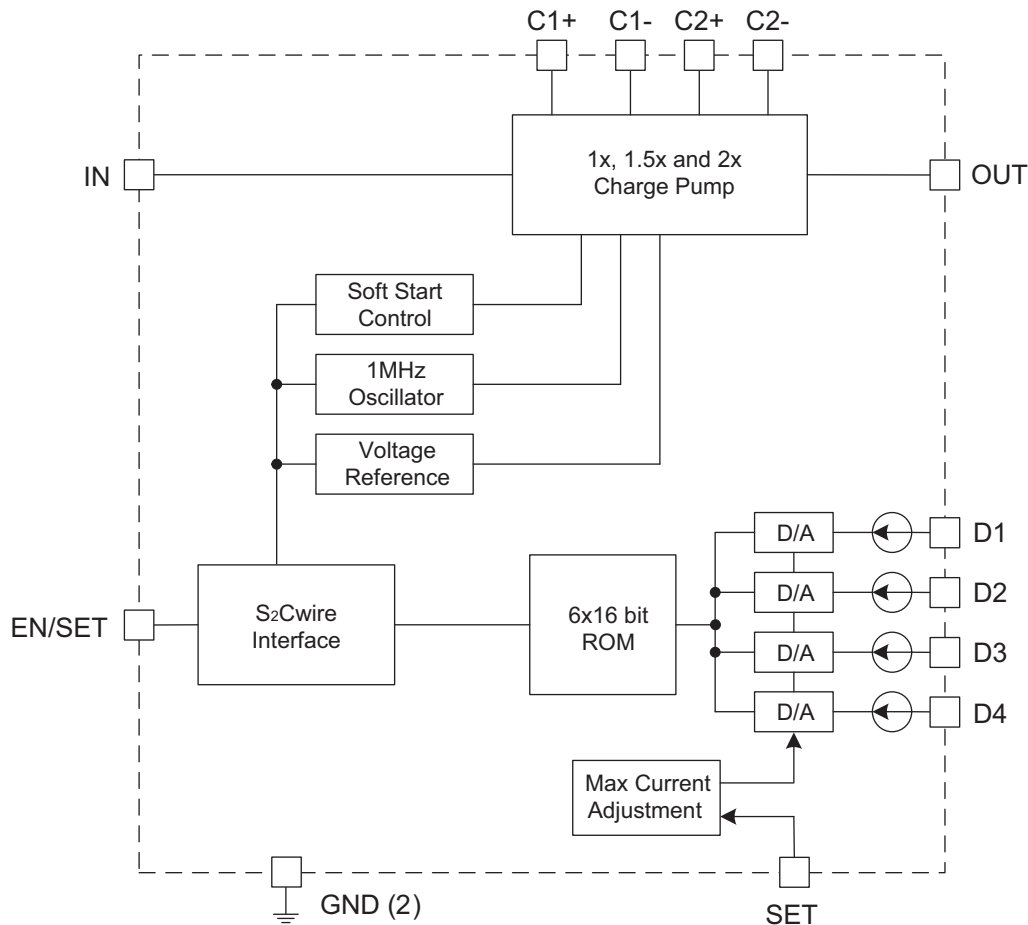

Functional Description

The AAT3159 is a tri-mode load switch (1X) and high efficiency (1.5X or 2X) charge pump device intended for white LED backlight applications. To maximize power conversion efficiency, an internal sensing circuit monitors the voltage required on each constant current sink input and sets the load switch and charge pump modes based on the input battery voltage and the current sink input voltage. As the battery discharges over time, the AAT3159 charge pump is enabled when any of the four current sink inputs nears dropout. The charge pump initially starts in 1.5X mode. If the charge pump output droops enough for any current source output to become close to dropout, the charge pump will automatically transition to 2X mode. The AAT3159 requires only four external components: two $1\mu\text{F}$ ceramic capacitors for the charge pump flying capacitors (C1 and C2), one $1\mu\text{F}$

ceramic input capacitor (C_{IN}), and one $0.33\mu\text{F}$ to $1\mu\text{F}$ ceramic output capacitor (C_{OUT}).

The four constant current sink inputs (D1 to D4) can drive four individual LEDs with a maximum current of 40mA each. The unused sink inputs must be connected to V_{OUT} ; otherwise, the part will operate only in 2X charge pump mode. The S²Cwire serial interface enables the AAT3159 and sets the LED current magnitudes.

Constant Current Output Level Settings

The LED current magnitude is controlled by AnalogicTech's S²Cwire serial digital interface. The maximum current is programmed by an external resistor at the SET pin. Since the current sinks are programmable, no PWM (pulse width modulation) or additional control circuitry is needed to control LED brightness. This feature greatly

ChargePump™ High Efficiency 1X/1.5X/2X Charge Pump for White LED Applications

reduces the burden on a microcontroller or system IC to manage LED or display brightness, allowing the user to “set it and forget it.” With its high-speed serial interface (1MHz data rate), the LED current can be changed successively to brighten or dim LEDs in smooth transitions (e.g., to fade-out) or in abrupt steps, giving the user complete programmability and real-time control of LED brightness. The code settings for the AAT3159 are listed in Table 1.

S²Cwire Serial Interface

The current level magnitude is controlled by AnalogicTech’s Simple Serial Control (S²Cwire) serial interface. The interface records rising edges of the EN/SET pin and decodes them into 16 different states. The 16 current level settings available are indicated in Table 1.

Data	All LED Outputs D1 - D4
1	100%
2	90%
3	79%
4	70%
5	62%
6	55%
7	48%
8	40%
9	31%
10	21%
11	15%
12	11%
13	1mA
14	500µA
15	100µA
16	50µA

Table 1: AAT3159 LED Current Levels as a Percentage of the Maximum Level Set by R_{SET}.

The S²Cwire serial interface has flexible timing. Data can be clocked-in at speeds greater than 1MHz, or much slower, such as 15kHz. After data is submitted, EN/SET is held high to latch the data. Once EN/SET has been held in the logic high state longer than T_{LAT} (500µs), the programmed current becomes active. For subsequent current level programming, the number of rising edges corresponding to the desired code must be entered on the EN/SET pin.

When EN/SET is held logic low longer than T_{OFF} (500µs), the AAT3159 enters into shutdown mode and draws less than 1µA from IN. The internal data register is reset to zero during shutdown.

Auto-Disable Feature

The AAT3159 is equipped with an auto-disable feature for each LED channel. After the IC is enabled and started up, a test current of 100µA (typical) is forced through each sink channel. The channel will be disabled if the voltage of that particular current sink (DX pin) does not drop to a specific threshold. This feature is very convenient for disabling an unused channel or during an LED fail short event.

Thermal Protection

The AAT3159 has built-in thermal protection circuit that will shut down the charge pump if the die temperature rises above the thermal limit, as is the case during a short-circuit event with the OUT pin.

S²Cwire Serial Interface Timing

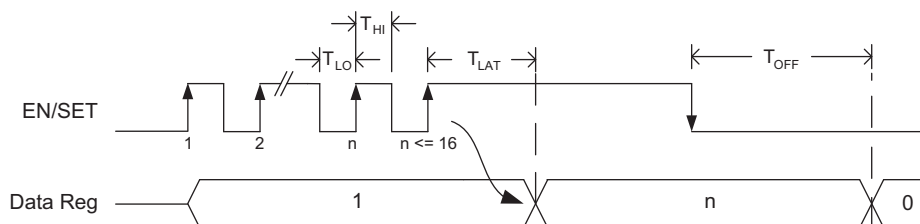

Applications Information

LED Selection

Although the AAT3159 is specifically intended for driving white LEDs, the device can also be used to drive most types of LEDs with forward voltage specifications ranging from 2.0V to 4.7V. LED applications may include main and sub-LCD display backlighting, camera photo-flash applications, color (RGB) LEDs, infrared (IR) diodes for remotes, and other loads benefiting from a controlled output current generated from a varying input voltage. Since the D1 to D4 input current sinks are matched with negligible voltage dependence, the LED brightness will be matched regardless of the specific LED forward voltage (V_F) levels. In some instances (e.g., in high-luminous-output applications such as photo flash), it may be necessary to drive high- V_F type LEDs. The low dropout current sinks in the AAT3159 make it capable of driving LEDs with forward voltages as high as 4.7V at full current from an input supply as low as 3.0V. Outputs can be paralleled to drive high-current LEDs without complication.

Determining the Maximum LED Current Level

The value of R_{SET} determines the maximum LED current level. In the typical application, selecting $R_{SET} = 26.1k\Omega$ results in 20mA/channel LED current. From this reference point, the R_{SET} value required for other current levels can be calculated as:

$$R_{SET} = \frac{20mA \cdot 26.1k\Omega}{I_{LED(MAX)}}$$

A visual representation of the maximum LED current per channel versus R_{SET} value is shown in Figure 1. Since the AAT3159's LED current control circuits were optimized for full-scale current settings higher than 15mA, R_{SET} values smaller than or equal to 33.2k Ω are recommended.

Brightness Control Using the SET Pin

Additional methods of brightness control can be achieved with the SET pin. For example, using an additional resistor to connect the SET pin with a digital output provides a HI/LO control. Figure 2 illustrates a configuration of the SET pin utilizing two resistors.

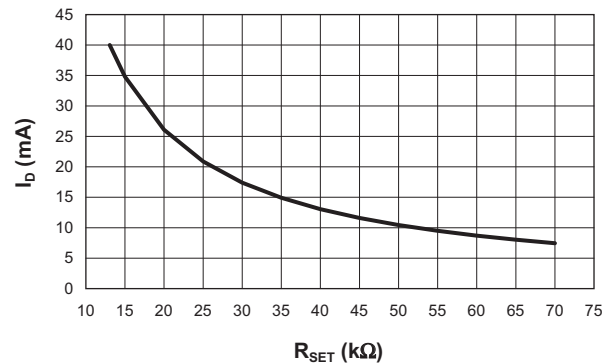

Figure 1: Maximum LED Current vs. R_{SET} .

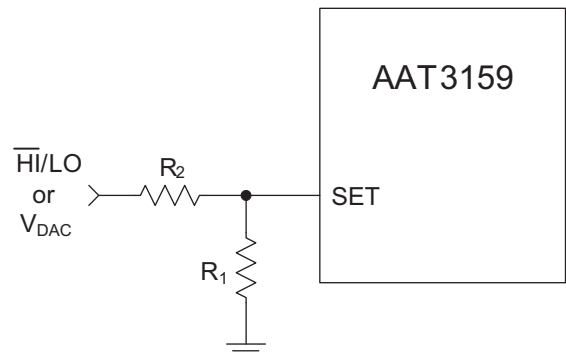

Figure 2: SET Pin Configuration Using Two Resistors.

When the digital output is asserted high, the resulting brightness level is LO and the individual LED currents are:

$$I_{LED(LO)} = I_{SET} \left(\frac{0.6V}{R_1 // R_2} - \frac{V_{IO}}{R_2} \right)$$

When the digital output is asserted low, the resulting brightness level is HI and the individual LED currents are:

$$I_{LED(HI)} = I_{SET} \left(\frac{0.6V}{R_1 // R_2} \right)$$

ChargePump™ High Efficiency 1X/1.5X/2X Charge Pump for White LED Applications

Additionally, a digital-to-analog converter can be used with the SET pin to control the brightness level. The result is like the equation above, where V_{I0} is replaced with V_{DAC} :

$$I_{LED(LO)} = I_{SET} \left(\frac{0.6V}{R_1 // R_2} - \frac{V_{DAC}}{R_2} \right)$$

For cases where PWM dimming is preferred, the PWM signal can be applied directly to the SET resistor, as shown in Figure 3. In order for the LED current to go to zero, the voltage level of the PWM signal must be higher than the SET pin voltage of 0.6V.

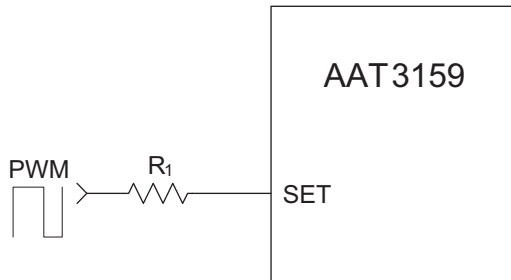

Figure 3: SET Pin Configuration for PWM Dimming Control.

Device Power Efficiency

The AAT3159's power conversion efficiency depends on the charge pump mode of operation. By definition, device efficiency is expressed as the output power delivered to the LEDs divided by the total input power consumed.

$$\eta = \frac{P_{LEDs}}{P_{IN}} = \frac{V_{LED1} \cdot I_{LED1} + \dots + V_{LED4} \cdot I_{LED4}}{V_{IN} \cdot I_{IN}}$$

When the input voltage is sufficiently greater than the LED forward voltages, the device optimizes efficiency by operating in 1X mode. In 1X mode, the device is working as a bypass switch and passing the input supply directly to the output. By simplifying the conditions such that the LEDs have uniform V_F , the power conversion efficiency can be approximated by:

$$\eta = \frac{P_{LEDs}}{P_{IN}} = \frac{V_{LED1} \cdot I_{LED1} + \dots + V_{LED4} \cdot I_{LED4}}{V_{IN} \cdot I_{IN}}$$

$$\eta = \frac{4 \cdot V_{LEDX} \cdot I_{LEDX}}{V_{IN} \cdot I_{IN}} ; x = 1, 2, 3 \text{ or } 4 \text{ and } I_{IN} = 4 \cdot I_{LEDX}$$

$$\eta = \frac{V_{LEDX}}{V_{IN}}$$

Due to the very low 1X mode quiescent current, the input current nearly equals the total output current delivered to the LEDs. Further, the low resistance bypass switch introduces a negligible voltage drop from input to output.

The AAT3159 further maintains optimized performance and efficiency by detecting when the input voltage is not sufficient to sustain the LED bias current. The device automatically switches to 1.5X mode when the input voltage drops too low in relation to the LED forward voltages.

In 1.5X mode, the output voltage can be boosted to 1.5X the input voltage. The 1.5X conversion ratio introduces a corresponding 0.5X increase in input current. For ideal conversion, the 1.5X mode efficiency is given by:

$$\eta = \frac{P_{LEDs}}{P_{IN}} = \frac{V_{LED1} \cdot I_{LED1} + \dots + V_{LED4} \cdot I_{LED4}}{V_{IN} \cdot I_{IN}}$$

$$\eta = \frac{4 \cdot V_{LEDX} \cdot I_{LEDX}}{V_{IN} \cdot I_{IN}} ; x = 1, 2, 3 \text{ or } 4 \text{ and } I_{IN} = 1.5(4 \cdot I_{LEDX})$$

$$\eta = \frac{V_{LEDX}}{1.5V_{IN}}$$

Similarly, when the input falls further, such that 1.5X mode can no longer sustain the LED bias currents, the AAT3159 will automatically switch to 2X mode. In 2X mode, the output voltage can be boosted to 2X the input voltage. The 2X conversion ratio introduces a corresponding 1X increase in input current. For ideal conversion, the 2X mode efficiency is given by:

$$\eta = \frac{P_{LEDs}}{P_{IN}} = \frac{V_{LED1} \cdot I_{LED1} + \dots + V_{LED4} \cdot I_{LED4}}{V_{IN} \cdot I_{IN}}$$

$$\eta = \frac{4 \cdot V_{LEDX} \cdot I_{LEDX}}{V_{IN} \cdot I_{IN}} ; x = 1, 2, 3 \text{ or } 4 \text{ and } I_{IN} = 2(4 \cdot I_{LEDX})$$

$$\eta = \frac{V_{LEDX}}{2V_{IN}}$$

Device Switching Noise Performance

The AAT3159 operates at a fixed frequency of approximately 1MHz to control noise and limit harmonics that can interfere with the RF operation of cellular telephone handsets or other communication devices. Back-injected noise appearing on the input pin of the charge pump is 20mV peak-to-peak, typically ten times less than inductor-based DC/DC boost converter white LED backlight solutions. The AAT3159 soft-start feature prevents noise transient effects associated with inrush currents during start-up of the charge pump circuit.

Capacitor Selection

Careful selection of the four external capacitors (C_{IN} , C_1 , C_2 , C_{OUT}) is important because they will affect turn-on time, output ripple, and transient performance. Optimum performance will be obtained when low equivalent series resistance (ESR) ceramic capacitors are used; in general, low ESR may be defined as less than 100m Ω . A value of 1 μ F for all four capacitors is a good starting point when choosing capacitors. If the LED current sources are only programmed for light current levels, then the capacitor size may be decreased.

Capacitor Characteristics

Ceramic composition capacitors are highly recommended over all other types of capacitors for use with the AAT3159. Ceramic capacitors offer many advantages over their tantalum and aluminum electrolytic counterparts. A ceramic capacitor typically has very low ESR, is lowest cost, has a smaller PCB footprint, and is non-polarized. Low ESR ceramic capacitors help maximize charge pump transient response. Since ceramic capacitors are non-polarized, they are not prone to incorrect connection damage.

Equivalent Series Resistance

ESR is an important characteristic to consider when selecting a capacitor. ESR is a resistance internal to a capacitor that is caused by the leads, internal connections, size or area, material composition, and ambient temperature. Capacitor ESR is typically measured in milliohms for ceramic capacitors and can range to more than several ohms for tantalum or aluminum electrolytic capacitors.

Ceramic Capacitor Materials

Ceramic capacitors less than 0.1 μ F are typically made from NPO or C0G materials. NPO and C0G materials typically have tight tolerance and are stable over temperature. Larger capacitor values are typically composed of X7R, X5R, Z5U, or Y5V dielectric materials. Large ceramic capacitors, typically greater than 2.2 μ F, are often available in low-cost Y5V and Z5U dielectrics, but capacitors greater than 1 μ F are typically not required for AAT3159 applications. Capacitor area is another contributor to ESR. Capacitors that are physically large will have a lower ESR when compared to an equivalent material smaller capacitor. These larger devices can improve circuit transient response when compared to an equal value capacitor in a smaller package size.

PCB Layout

To achieve adequate electrical and thermal performance, careful attention must be given to the printed circuit board (PCB) layout of the AAT3159. Figures 5 and 6 illustrate an example PCB layout for the AAT3159 (evaluation board). The flying capacitors (C_1 and C_2), input capacitor (C_4), and output capacitor (C_3) should be connected as close as possible to the IC. In addition to the external passive components being placed as close as possible to the IC, all traces connecting the AAT3159 should be as short and wide as possible to minimize path resistance and potential coupling.

Evaluation Board Schematic

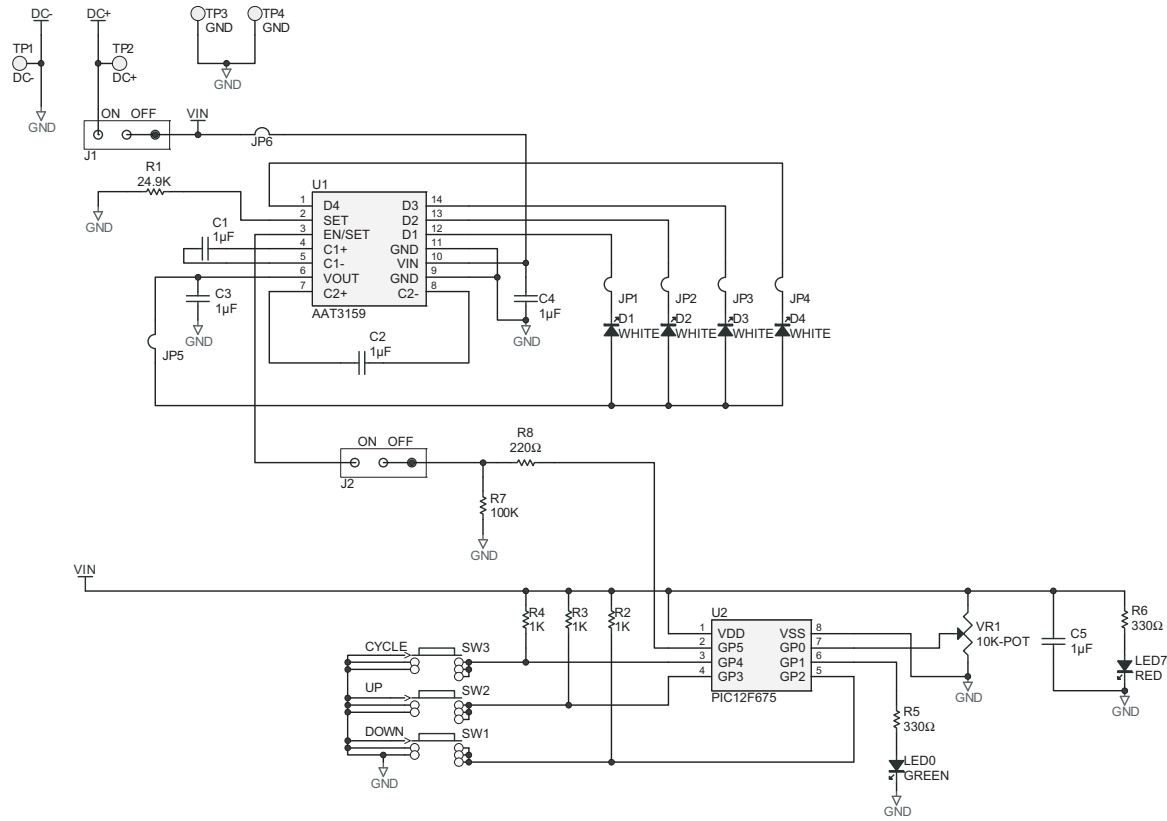

Figure 4: AAT3159 Evaluation Board Schematic.

Evaluation Board Layout

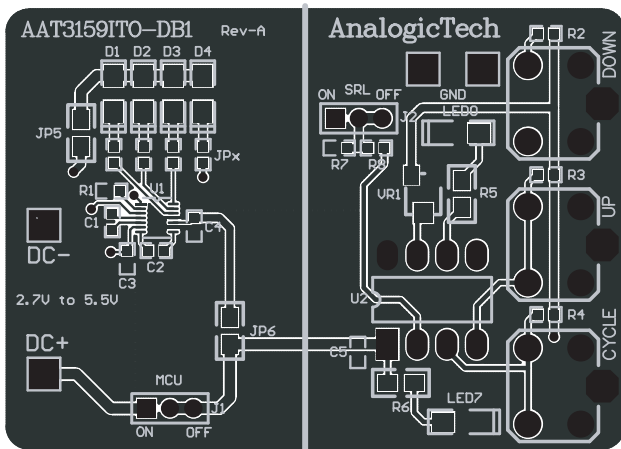

Figure 5: AAT3159 Evaluation Board Top Side Layout.

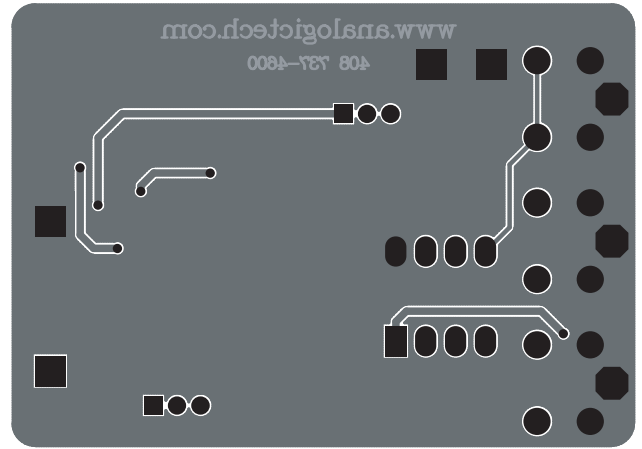

Figure 6: AAT3159 Evaluation Board Bottom Side Layout.

ChargePump™ High Efficiency 1X/1.5X/2X Charge Pump for White LED Applications

Ordering Information

Package	Marking ¹	Part Number (Tape and Reel) ²
TSOPJW-14	TLXYY	AAT3159ITO-T1



All AnalogicTech products are offered in Pb-free packaging. The term “Pb-free” means semiconductor products that are in compliance with current RoHS standards, including the requirement that lead not exceed 0.1% by weight in homogeneous materials. For more information, please visit our website at <http://www.analogictech.com/pbfree>.

Package Information

TSOPJW-14

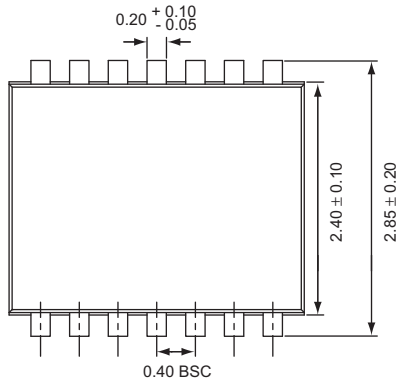

Top View

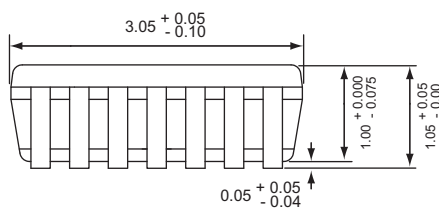

Side View

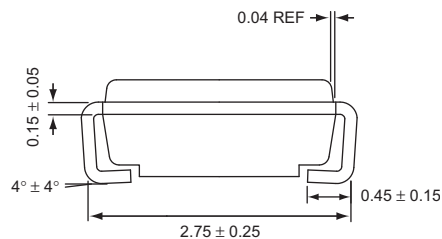

End View

All dimensions in millimeters.

1. XYY = assembly and date code.
 2. Sample stock is generally held on part numbers listed in **BOLD**.

**AAT3159****ChargePump™****High Efficiency 1X/1.5X/2X Charge Pump for White LED Applications**

Advanced Analogic Technologies, Inc.
3230 Scott Boulevard, Santa Clara, CA 95054
Phone (408) 737-4600
Fax (408) 737-4611



© Advanced Analogic Technologies, Inc.
AnalogicTech cannot assume responsibility for use of any circuitry other than circuitry entirely embodied in an AnalogicTech product. No circuit patent licenses, copyrights, mask work rights, or other intellectual property rights are implied. AnalogicTech reserves the right to make changes to their products or specifications or to discontinue any product or service without notice. Except as provided in AnalogicTech's terms and conditions of sale, AnalogicTech assumes no liability whatsoever, and AnalogicTech disclaims any express or implied warranty relating to the sale and/or use of AnalogicTech products including liability or warranties relating to fitness for a particular purpose, merchantability, or infringement of any patent, copyright or other intellectual property right. In order to minimize risks associated with the customer's applications, adequate design and operating safeguards must be provided by the customer to minimize inherent or procedural hazards. Testing and other quality control techniques are utilized to the extent AnalogicTech deems necessary to support this warranty. Specific testing of all parameters of each device is not necessarily performed. AnalogicTech and the AnalogicTech logo are trademarks of Advanced Analogic Technologies Incorporated. All other brand and product names appearing in this document are registered trademarks or trademarks of their respective holders.